



**HOLME
DODSWORTH
METALS^{LTD}**

Global sourcing
for local needs



HOLME
DODSWORTH
METALS^{LTD}





Welcome to a world of metal

Holme Dodsworth Metals Ltd is one of the UK's largest importers and distributors of non-ferrous metals. Founded in 1879, our current operation remains a UK-family-owned and run business, proudly supplying industry for over 140 years. **Our reputation is built on providing consistent quality, dependable delivery, and exceptional service levels - a commitment reflected in our outstanding Net Promoter Scores (NPS) and the fact that so many of our customers actively recommend us.**

In an ever-changing market, we focus on sourcing the highest-quality materials from around the world, ensuring every product we supply meets rigorous standards. Our goal is simple: to give you access to an extensive product range, backed by responsive service and competitive pricing.

With a growing national presence and eight dedicated sales and distribution hubs - Basingstoke, Bristol, Manchester, Newcastle, Plymouth, Rotherham, Walsall, and Witham (Essex) - **we are positioned to be a reliable, long-term partner in your supply chain.**

your nationwide
multi-metal stockist

contents

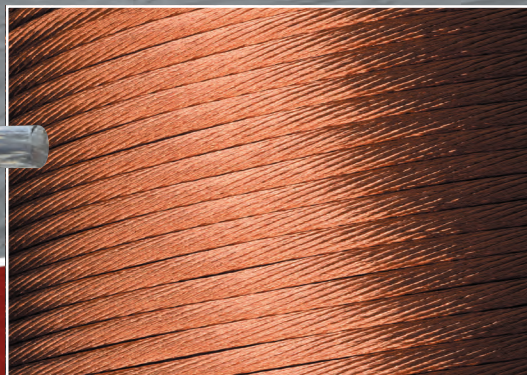



contents

brass	5
copper	7
copper nickel	9
bronze	11
stainless steel	13
aluminium	15
cast iron	17
speciality metals	19
quality	21
processing	23
location map	25

We pride ourselves on offering one of the most extensive selections of metals, sizes, shapes, and finishes in the UK. Across our branch network, we carry substantial stocks of the most in-demand specifications, ensuring we can meet the needs of every industry we serve.

Operating to **ISO 9001** standards, we offer both **local deliveries** and **daily inter-branch transfers** - giving you fast, dependable access to the materials you need. Our **eight strategically located hubs** - Basingstoke, Bristol, Manchester, Newcastle, Plymouth, Rotherham, Walsall, and Witham (Essex)—are linked by a seamless stock management system, enabling rapid response to customer requirements.

You can review this brochure or explore our product range online at **www.holmedodsworth.com**, where you'll find details on the metals we supply and the tailored solutions we provide.

For a competitive spot price, a review of mill or stockholder call-offs, or to discuss commercial consignment stock arrangements, simply call or email one of our friendly and knowledgeable sales teams.

brass

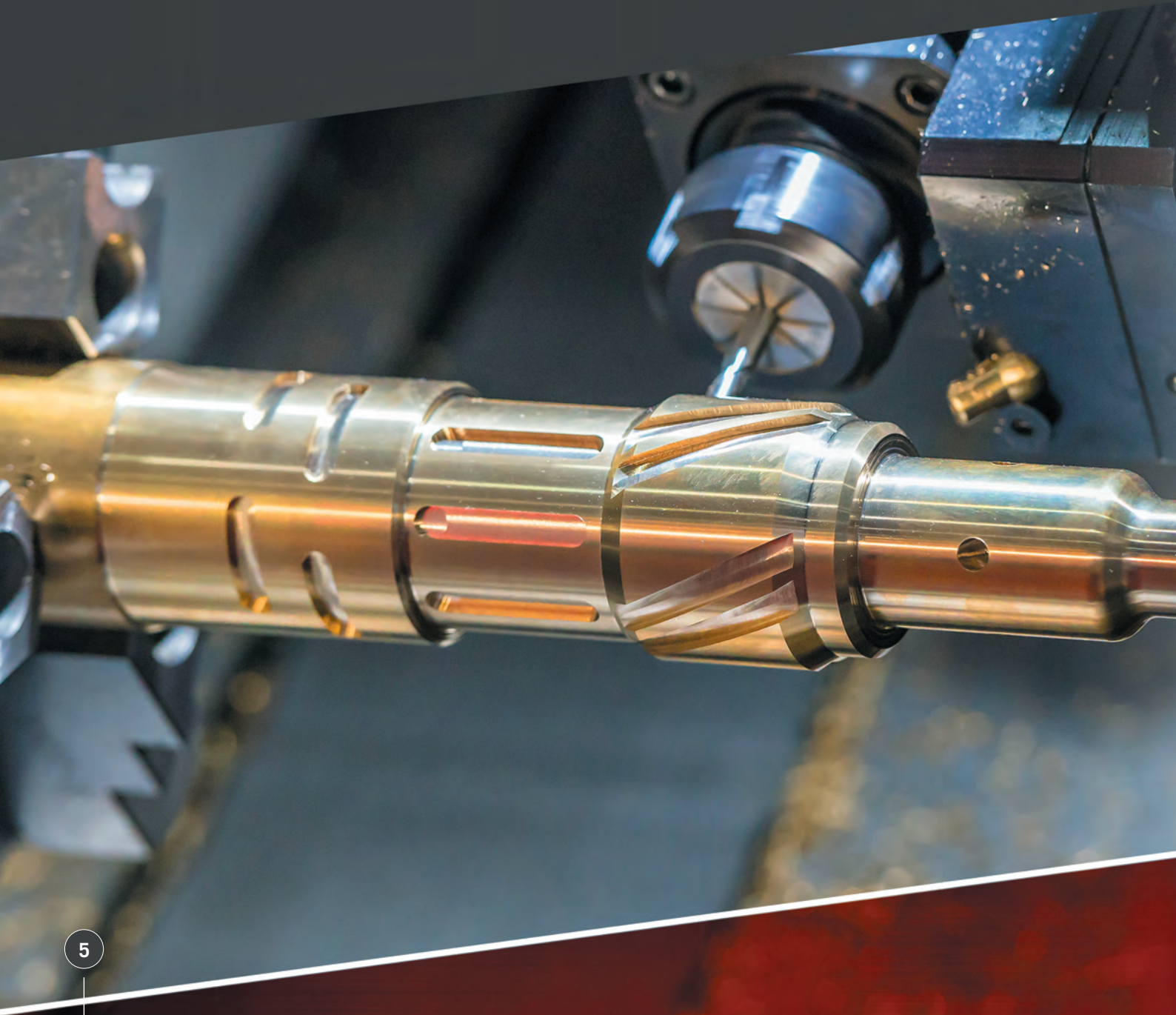



brass stock

Round ●

Flat —

Square ■

Hexagon ●

Tee T

Box □

Angle L

Channel U

Tube ○

Sheet & Plate ≡

Profiles ⚙

Brass - an alloy of copper and zinc - is one of the most widely used of all copper-based metals thanks to its combination of strength, machinability, and corrosion resistance. By adding small amounts of elements such as lead, tin, aluminium, manganese, or silicon, we can enhance specific properties including wear resistance, ductility, and cold formability. This versatility ensures brass is a go-to material for industries including automotive, aerospace, marine, naval, chemical, electrical, and plumbing.

At Holme Dodsworth, our brass range is extensive - not only in grade selection but also in the variety of forms and sizes we carry. Stocked grades include free machining brass, naval brass, high-tensile brass, riveting brass, stamping brass, low-lead brass, and dezincification-resistant brass. For non-standard grades or sizes, our global sourcing network ensures we can supply exactly what you need.

Typical Grades:

- CZ101 • CZ106 • CZ108 • CZ109 • CZ110 • CZ112 • CZ114 • CZ115
- CZ120 • CZ121 • CZ122 • CZ126 • CZ129 • CZ130 • CZ131 • CZ132
- CW501L • CW505L • CW508L • CW509L • CW702R • CW712R
- CW721R • CW722R • CW608N • CW612N • CW614N • CW617N
- CW707R • CW611N • CW601N • CW606N • CW624N • CW602N

copper



copper stock

Round bar 

Wire 

Flat 

Tube 

Sheet & Plate 

Square 

Profiles 

Our copper products are sourced from some of the world's most reputable mills, ensuring exceptional quality and consistency. We stock a wide range of grades - from oxygen-free copper to ETP and free machining grades - available in multiple forms including round bar, flat bar, sheet, plate, and tube. This breadth of supply means our copper range is among the most comprehensive in the UK.

Naturally ductile and corrosion-resistant, copper also delivers excellent electrical and thermal conductivity. Small alloying additions can enhance strength and machinability, making it a highly versatile choice for numerous industries.

Much of our copper is supplied for use as **busbars** in switchgear, as well as in the power generation, electrical, and telecommunications sectors, where conductivity is critical. It is also ideal for producing valve and pipe fittings, chemical processing equipment, architectural profiles, electronic components, cookware, and biomedical equipment.

Typical Grades:

- C101 • C103 • C106 • C107 • C109 • C110 • C111 • CC101 • CC102
- CW004A • CW008A • CW024A • CW118C • CW009A • CW114C
- CC105C • CC106C • CW011A • CW012A • CW013A

copper nickel



copper nickel stock

Round bar ●



Our copper nickel alloys are sourced from leading global producers, offering proven performance in the most demanding service conditions. Combining the corrosion resistance of copper with the strength and durability of nickel, these alloys are widely used in **marine, offshore, defence, desalination, and heat exchanger applications.**

Copper nickel delivers outstanding resistance to seawater corrosion, biofouling, and stress cracking. It also offers excellent thermal conductivity and stable mechanical properties over a wide temperature range, making it ideal for shipbuilding, power generation, and cooling systems.

We hold comprehensive stocks in both **90/10** and **70/30** compositions, available in multiple forms and sizes for rapid supply. For specialist requirements, we can also source non-standard sizes and grades quickly via our global supply network.

Quality & Certification

- DEF STAN specifications for naval and marine use
- 3.2 Certification via Lloyd's available on request

Typical Grades:

- CN102 • CN109 • CW352H • CW354H • C70600
- C71500 • NES 747 • DEF STAN 02-780
- Copper Nickel 90/10 • Copper Nickel 70/30

bronze



bronze stock

Round bar 

Hexagon 

Square 

Hollow 

Flat bar 

Plate 

Quality & Certification

- DEF STAN specifications for naval and marine use
- 3.2 Certification via Lloyd's available on request

We carry a comprehensive range of bronze products, focusing on three key families: **aluminium bronze**, **phosphor bronze**, and **leaded bronze (gunmetal)**. Each offers distinct mechanical and physical benefits, making them suitable for a wide range of engineering applications.

Phosphor bronze - an alloy of copper and tin - provides excellent wear resistance, corrosion resistance, and medium strength, while maintaining the traditional bronze appearance. It is available in wrought forms including round, hexagon, flat, square, sheet, and plate.

Leaded bronze (gunmetal) offers good corrosion resistance, ease of casting, and reliable mechanical strength, and is stocked in round bar and thick-walled tube.

Aluminium bronze - containing copper, aluminium, and varying levels of nickel and iron - is known for its high strength, excellent corrosion resistance (especially in marine environments), and superior wear resistance under load. It is stocked primarily in round, hexagon, and plate, with a golden-bronze appearance.

Typical Grades:

- AB2 • CA104 • NES833 • NES834 • DSTAN 02-833 • DSTAN 02-834
- PB1 • PB2 • CUSN12 • PB102 • LG2 • LB4 • SAE660
- CC333G • CW307G • CW301G • C63000 • AMS4640
- CC481K • CC483K • CW451K • CC491K • CC494K

stainless steel



stainless stock

Round bar ●

Flat —

Sheet & Plate ≡

Square ■

Hexagon ⬡

Tube ○

Box □

Angle L

Stainless steel is an iron-based alloy containing a minimum of 10.5% chromium, with varying levels of carbon, silicon, and manganese. Additional elements such as nickel, molybdenum, copper, and tungsten are added to enhance specific qualities including strength, formability, and corrosion resistance.

This versatility allows stainless steel to be used in a wide range of sectors, from architecture and catering to energy, oil and gas, power generation, and transport. Each grade offers its own balance of mechanical and physical properties - ranging from the non-magnetic austenitic grades and magnetic martensitic grades, to specialist precipitation hardening, duplex, and super duplex alloys.

We stock an extensive selection in multiple grades, forms, and finishes to meet diverse application needs. Customer-specific specifications can also be sourced and supplied quickly through our trusted network.

Typical Grades:

- 303 • 304 • 304L • 316 • 316L • 321 • 416 • 420 • 431 • 440C • 17/4PH
- 1.4305 • 1.4301 • 1.4304 • 1.4307 • 1.4401 • 1.4404 • 1.4541
- 1.4005 • 1.4057 • 1.4021 • 1.4125 • 1.4542 • S17400
- S31254 • S31803 • S32550 • S32750 • S32760
- F44 • F51 • F53 • F55 • F61

aluminium





aluminium stock

Round bar ●

Angle L

Channel □

Tee T

Flat —

Tube ○

Sheet & Plate ≡

Hexagon ◆

Square ■

Box □

Aluminium and its alloys are among the most widely used non-ferrous materials, thanks to their unique balance of strength, low weight, and cost efficiency. Alongside these core benefits, aluminium offers excellent corrosion resistance, high conductivity, and good machinability and workability. This makes it an essential choice for general and high-performance engineering, as well as aerospace, automotive, structural, and decorative applications.

We carry a large and varied aluminium stock range, from basic round and flat bar to plate, sheet, and section, as well as complex extrusions. Available grades range from higher-purity alloys to advanced compositions incorporating magnesium, manganese, silicon, tin, and copper - delivering increased strength or machinability. Many extruded profiles are produced to customer-specific tolerances and held in stock for call-off.

Typical Grades:

- 1050 • 1080 • 1200 • 2011 • 2014 • 5083 • 5251 • 6063
- 6061 • 6026 • 6082 • 6101 • 6262 • 7020 • 7075
- S1B • S1A • S1C • FC1 • H15 • NE8 • NE4 • HE9
- HE20 • HE30 • E91E • HE20 • HE17 • L95

cast iron





cast iron stock

Round bar ●

Flat —

Square ■

Continuous cast section ■

Our cast iron range includes both grey iron and nodular (ductile) iron, providing a balance of strength, wear resistance, and machinability to meet a wide range of engineering needs.

Grey iron offers good vibration damping and stability, making it ideal for machine bases, tooling, and components where dimensional accuracy is essential. Nodular iron delivers greater ductility and impact resistance, making it the preferred choice for high-stress mechanical applications.

We also stock Ni-Resist grades for applications requiring enhanced corrosion and heat resistance, commonly used in marine, pump, and valve industries. All grades are sourced from trusted producers and are available ex-stock in various sizes and profiles, with full certification available on request.

Typical Grades:

• Grade 250 • 400/15 • 500/7 • 600/3 • Ni-Resist

speciality metals





typical products stocked

Tool steels

Engineering steels

Nickel alloys

Titanium

Engineering plastics

Castings and forgings

Round bar ●

Flat —

Tube ○

Sheet & Plate ≡

Hexagon ◆

Our range of speciality metals complements our core non-ferrous stock, giving customers a **true multi-metal solution** from a single supplier. All products are sourced from trusted producers and held in stock in a variety of forms and sizes for fast delivery.

We carry a wide selection of tool and engineering steels, available in both quenched and tempered or rolled condition. These are offered mainly in round and flat bar and can be supplied with 3.2 certification via Lloyd's upon request.

Our nickel alloy and titanium ranges deliver high strength, corrosion resistance, and exceptional performance at elevated temperatures - making them well suited for aerospace, marine, chemical processing, and specialist engineering applications.

We can also offer **specialist castings and forgings** if required, giving you access to tailored solutions for more complex engineering projects.

In addition, we can offer engineering plastics in various grades to suit industrial and fabrication requirements. If you require a grade or form not listed, our team can source it quickly through our global supply chain.

Typical Grades:

- 01 • D2 • H13 • 1.2379 • 1.2344 • 1.2510
- EN1A • EN3A • EN3B • EN8 • EN19 • EN24
- 230M07 • 070M20 • 080M40 • 709M40 • 817M40
- Alloy 400 • Alloy K500 • Alloy 600 • N31 • TI GR 2 • TI GR 5

quality assured





Certificate No.11067



At Holme Dodsworth Metals, quality is at the heart of everything we do. We are **UKAS accredited to ISO 9001:2015**, **JOSCAR registered**, **Cyber Essentials certified**, and **CBAM compliant** - demonstrating our commitment to the highest standards of product quality, data security, regulatory compliance, and supply chain assurance. Our objective is simple - **to consistently meet or exceed customer expectations**.

Our integrated Quality Management System works seamlessly with our bespoke ERP platform to define quality standards, monitor performance, and drive continuous improvement. We analyse our results against clearly defined objectives, ensuring that our processes evolve to meet changing customer and market demands.

Regular management reviews provide the framework for identifying and implementing improvements—whether in product quality, service levels, or working practices. This proactive approach ensures that our customers receive not only the right product, but the highest standard of service, every time.

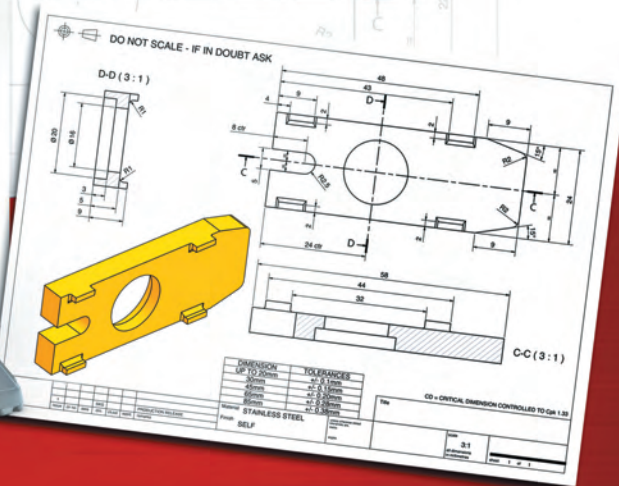
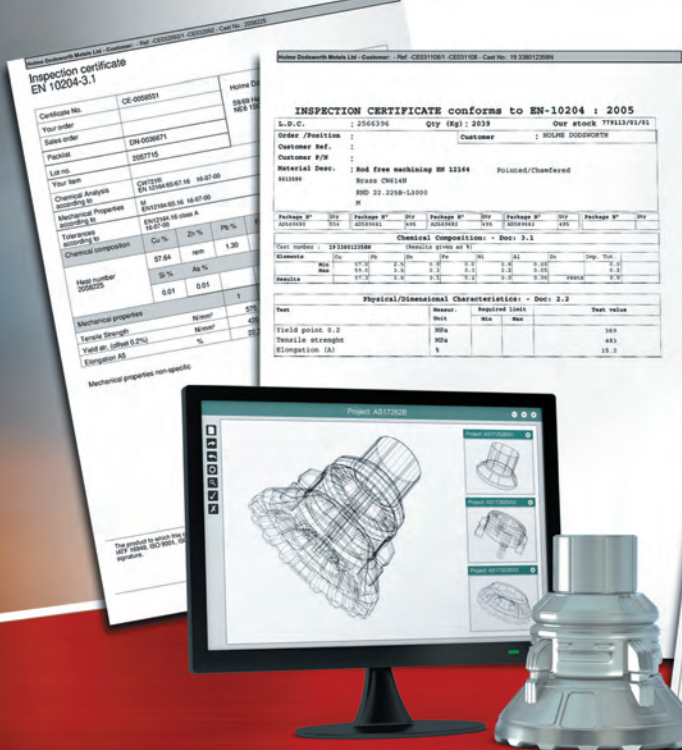

100% of the time

processing & delivery



Processing and delivery services
that complement our vast range
of stock materials



services

- **Bar and Plate Cutting**
- **Polishing**
- **Tinning**
- **Grinding**
- **Machining**
- **Heat Treatment**
- **Coating**
- **Testing**
- **Local and National Delivery**

We have invested in a wide range of in-house processing facilities to make purchasing, delivery, and production as efficient as possible for our customers. From a single cut length up to 20" dia to large contract orders, we can process materials so they're ready for immediate use.

In addition to our own capabilities, we work with approved specialist partners for services including precision grinding, slitting, machining, polishing, coating, tinning and testing - ensuring the highest quality results for every order.

Thanks to the strategic locations of our nine UK hubs, we can process and dispatch orders quickly via our own delivery fleet or trusted national next-day courier services. If you prefer to collect, all sites can prepare material for pickup—often within the hour.

As a UKAS ISO 9001:2015 accredited, JOSCAR registered, Cyber Essentials certified, and CBAM compliant supplier, we ensure that every stage of processing and delivery meets rigorous quality, security, and compliance standards.

locations



**HOLME
DODSWORTH
METALS^{LTD}**

**8 dedicated sales and distribution hubs –
nationwide coverage, local service.**

With eight strategically located sales and distribution hubs across the UK, we can stock, locate, and deliver materials quickly and efficiently to any part of the country. Our network includes all of the sites marked on the map.

This nationwide footprint means our customers benefit from **local support backed by national resources.**

Whether it's a same-day collection, a scheduled delivery, or a fast turnaround on an urgent requirement, our hubs work together to keep your supply chain moving without delay.



- Branches
- Distribution hubs

Supplying metals to the industries that keep the world moving

Holme Dodsworth Metals supplies high-quality metals and alloys to a wide range of sectors across the UK and Europe. Our breadth of stock, processing capabilities, and nationwide distribution network allow us to meet the demands of industries where performance, reliability, and service are critical.

From high-volume production to specialist one-off projects, our products and services are trusted in applications where quality and consistency cannot be compromised. Whatever your industry, we are ready to be your reliable partner in supply.

- Tube, Sheet & Heat Exchanger Manufacturing
- Laser Cutting, Waterjet & Fabrication
- Electrical, Electronics, Busbar & Switchgear
- Automotive, Transportation & Motorsport
- Marine & Shipbuilding
- Precision Engineering & CNC Machining
- Defence
- Architectural & Infrastructure Projects
- Energy, Oil & Gas
- Medical Equipment
- Power Generation



HOLME DODSWORTH METALS^{LTD}

Brass • Copper • Copper Nickel • Bronze • Stainless Steel
• Aluminium • Cast Iron • Speciality Metals

- Basingstoke
- Bristol
- Manchester
- Newcastle upon Tyne *(Head Office)*
- Plymouth
- Rotherham
- Walsall
- Witham (Essex)



holmedodsworth.com



Certificate No.11067